

Superconducting transmission lines for use in a ^3He dilution refrigerator

Ashley Kibel

Arizona State University, Tempe, Arizona 85283

W. G. Clark

Dept. of Physics and Astronomy, University of California at Los Angeles, Los Angeles, 90095-1547

We compare two superconducting transmission lines for use in a ^3He dilution refrigerator using a NbTi wire inner conductor with NbTi foil and CuNi tubing outer conductors. The heat transfer is calculated using the Wiedermann-Franz Law, and the impedance and power loss are measured using a network analyzer at room temperature and at 4K. The transmission line with CuNi tubing is easy to construct, transfers little heat, and has an impedance closer to $50\ \Omega$ than the line with NbTi foil outer conductor.

Introduction

Many ultra low temperature experiments make use of a ^3He dilution refrigerator, which usually operates in the temperature (T) regime of 0.02 to 0.5 K. The ^3He dilution refrigerator creates temperatures of this order by making use of the ^3He , ^4He phase transition at .87 K. This phase transition separates the ^3He , ^4He mixture into a ^3He rich phase and ^4He rich phase. Pumping on the ^4He rich phase generates a flow of ^3He across the phase boundary from the ^3He -rich phase (low entropy) to the ^3He -dilute phase (high entropy that absorbs heat, thereby cooling the mixture and the mixing chamber that contains it [1].

At low temperatures, an additional heat load of $10\ \mu\text{W}$ can significantly increase the lowest temperature obtained with a small dilution refrigerator. For this reason, it is important for many radio frequency (RF) measurements, such as nuclear magnetic resonance (NMR), to have a section of RF cable at low temperatures that has good RF performance: i.e., a characteristic impedance close to $50\ \text{Ohms}$, low RF attenuation (low electrical resistance), and a low thermal conductivity

A problem arises when attempting to transfer RF power into this dilution refrigerator system. A typical transmission line made of copper will have the affect of transferring heat into the system, and thus the temperature of the mixing chamber will increase. This is because copper, as a metal and very good electrical conductor, is also a good conductor of thermal energy. The thermal conductivity is governed by the Wiedermann-Franz

law, which relates the thermal conductivity to the electrical conductivity by

$$\frac{K}{\sigma} = \frac{\pi^2}{3} \left(\frac{k_B}{e} \right)^2 T, \quad (1)$$

where K is the thermal conductivity, σ is the electrical conductivity, k_B is Boltzmann's constant, and e is the electronic charge [2]. Thus, in order to maintain high electrical conductivity, while reducing heat transfer, another type of material must be used.

In our transmission lines, the superconducting alloy NbTi is used for the center conductor of a coaxial cable. NbTi, which is an alloy superconductor, has a high electrical conductivity and a low thermal conductivity. We then make two different lines, one with a CuNi tubing outer conductor and another with a NbTi foil outer conductor and test both the losses attributed to each line and the impedance of the lines with a network analyzer at room temperature and at 4K in liquid Helium. Since these lines are to be connected to other transmission lines of $50\ \Omega$ impedance, it is crucial that these lines have impedances close to $50\ \Omega$ as well. The cable with the CuNi tubing was found to be easily constructed, transferring little heat, and closely matching the $50\ \Omega$, and therefore, will be the better cable for use in the dilution refrigerator.

This paper discusses many of the basic considerations in transmission line theory, explains the construction of the two different coaxial cables and, lastly, describes the reflection tests using a network analyzer on the transmission lines at room temperature, and submersed in liquid helium.

Transmission Lines

A transmission line carries an electrical signal from one point to another. In our lines, we use a coaxial transmission line. A coaxial transmission line is constructed using two concentric cylinders, separated by a dielectric. Current flows down the inner cylinder in one direction, and flows down the inside of the outer cylinder in the opposite direction. This creates an electrical field and magnetic field that are perpendicular to each other, and are also perpendicular to the propagation direction of the electromagnetic wave. This is called the TEM (transverse electric and magnetic) mode, and can only occur in a transmission lines utilizing two conductors.

Figure 1 shows the basic circuit diagram for a TEM mode transmission line. For a line with only small losses the characteristic impedance can be modeled [3],

$$Z_0 = \sqrt{\frac{R + j\omega L}{G + j\omega C}} \approx \sqrt{\frac{L}{C}} \left(1 + j \frac{1}{2} \left(\frac{G}{\omega C} - \frac{R}{\omega L} \right) \right), \quad (2)$$

where R is the resistance per unit length, G is the conductance per unit length, C is the capacitance per unit length, L is the inductance per unit length and ω is the frequency..

From this, we can use the approximation [3]

$Z_0 = \sqrt{\frac{L}{C}}$, where L and C are the inductance and capacitance per unit length respectively, assuming that resistance and conductance per unit length are small.

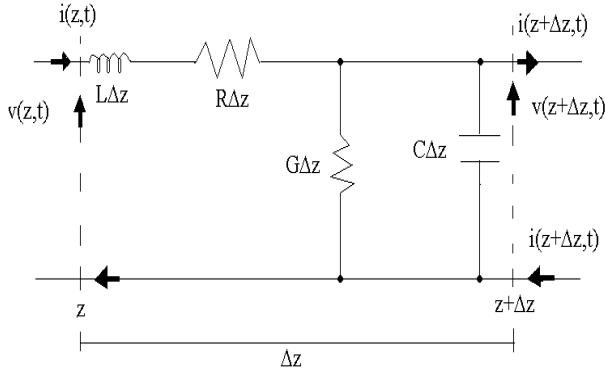

FIG. 1: Transmission line circuit diagram.

The reflection coefficient at the termination of a transmission line is equal to the phasor value of the reflected voltage wave at the termination, divided by the phasor value of the incident voltage wave at

the termination. We use the equation for the reflection coefficient [3]

$$\rho_T = \frac{Z_T - Z_0}{Z_T + Z_0}, \quad (3)$$

Where Z_T is the termination impedance, and Z_0 is the characteristic impedance of the transmission line.

Therefore, if the impedance at the termination is equal to the characteristic impedance of the line, there will be no reflection at the point of termination, and the entire wave will be transmitted. If the line is shorted and has zero attenuation, there will be no attenuation of the reflected wave.

Construction of the Coaxial Cables

For both transmission lines, a single filament 0.011 in. diameter copper clad NbTi wire is used for the inner conductor. NbTi is a type II superconducting alloy, and as such, can maintain its superconducting properties at higher critical fields than a type I superconductor. Because of its mechanical flexibility, high critical current, and moderately high upper critical field, multifilament NbTi is used to carry the current in most commercial superconducting magnets. Furthermore, as a superconductor it has very low thermal conductivity and zero electrical resistance below its critical temperature.

The copper clad on the wire will transfer heat into the dilution refrigerator. For this reason, nitric acid is used to remove the copper clad along the length of the wire, except in small segments. Those segments are left for soldering purposes, since NbTi is difficult to solder.

One of the transmission lines was constructed with a 40 μm thick NbTi foil for the outer conductor. A transmission line using this foil would then have superconductors for the inner conductor and outer conductor, and the heat transfer into the dilution refrigerator would be minimized, while maximizing the electrical conductivity at low temperatures. Epoxy fiberglass was cut into small strips and sealed with a thin space left in between as in figure 2. The foil is then folded into a cylindrical shape, with the edges held together with the fiberglass mold.



FIG.2: Epoxy fiberglass forms a mold to hold the two edges of the NbTi foil together. The NbTi wire is inserted inside the cylinder of NbTi foil

Since, like the NbTi wire, the NbTi foil is difficult to solder, two small slits are cut at each end of the line. These slits are then scraped with a scalpel to remove any oxidation and copper tubing is firmly pressed around these slits to make an electrical connection. This copper tubing is then able to solder to the outer conductor of another segment of transmission line. This feature is shown in the upper right of Fig. 3, where the crimped Cu tube is covered with solder. In what follows, the transmission line with NbTi outer and inner conductor will be referred to the NbTi coax or transmission line.

For the other coaxial cable, a CuNi tube with a diameter of 3/64 in. and a wall thickness of 0.007 in. is used for the outer conductor. CuNi is a normal metal and will transfer heat like a normal conductor. It has, however, a measured resistance on the order of 1 Ω /m at room temperature. Because it is a disordered alloy, its resistance at low temperatures has a similar value. Also, since it is a normal metal, the Wiedermann-Franz Law can be used to obtain the corresponding thermal conductivity. It then follows, for example, that if its length is 30 cm and the high temperature side is anchored to 4.2 K, the heat transferred to the mixing chamber of the dilution refrigerator is less than one microwatt. This amount of heat transfer is not enough to increase significantly the temperature of the dilution refrigerator.

In what follows, the transmission line with CuNi outer conductor and NbTi inner conductor will be referred to as the CuNi coax or transmission line. Both the NbTi line and the CuNi line are shown in figure 3.

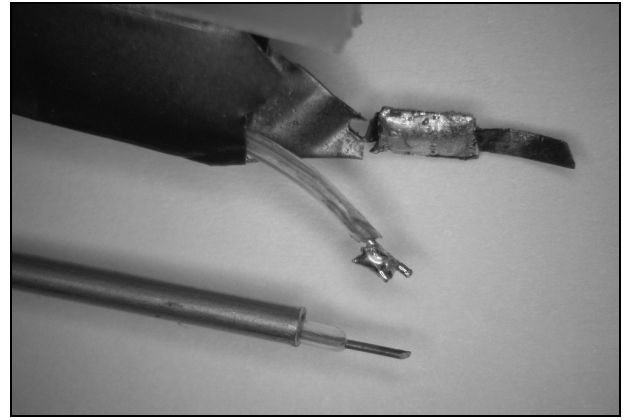

FIG. 3: Magnified photographs of both test transmission lines. Top: NbTi foil transmission line Bottom: CuNi tubing transmission line

For both of the transmission lines, a Teflon tube with an outside diameter of 0.027 in. and an inside diameter of 0.015 in. was used for the dielectric. The NbTi wire is threaded through this tubing and the tubing is inserted into the outer conductor. Teflon has a dielectric constant of 2.2, which is used in determining the capacitance per unit length of the transmission lines, and thus, the characteristic impedance.

RF Properties of the Cables

The information needed regarding the properties of the cables is their characteristic impedance attenuation as a function of frequency at low temperatures. These measurements were made by connecting the superconducting cables to a 1.3 m length of 0.085 in. outside diameter semirigid commercial 50 Ω coaxial cable. A BNC jack was attached to the opposite end and used to connect the cable to an Agilent 8714 AT RF network analyzer. This arrangement permitted measurements of the reflected power at the end of the semirigid coax away from the SC transmission line over the frequency range 1 MHz to 2 GHz. With this arrangement, measurements were made with the SC transmission line at room temperature and, by inserting it into a helium storage dewar, at 4.2 K.

A sketch of this cable system is shown in Fig. 4. The general approach was to measure the loss in the semirigid coax by recording the reflected power when the cable was short circuited at point B. Then, the same measurement was made by removing the short at point B and short circuiting the transmission line at point A to obtain the reflected power for both the SC transmission line and the

semirigid coax cable. Ideally, subtracting these results then gives the loss in just the SC transmission line. Finally, a measure of the characteristic impedance of the SC transmission line was obtained by terminating it with a $50\ \Omega$ chip resistor and measuring the reflected power as a function of frequency. Now we present the results.

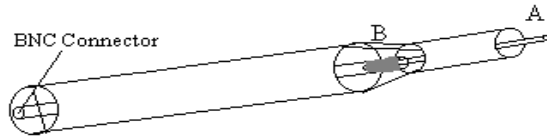
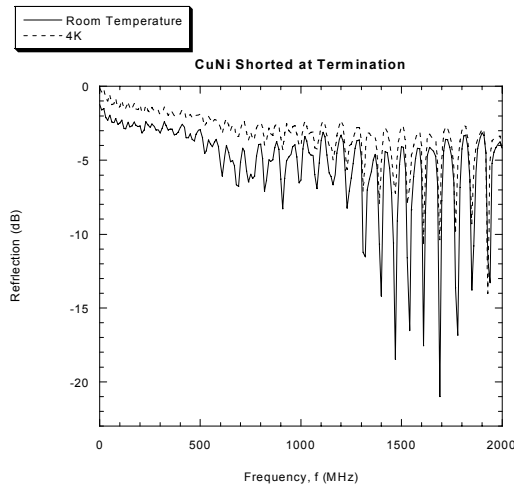
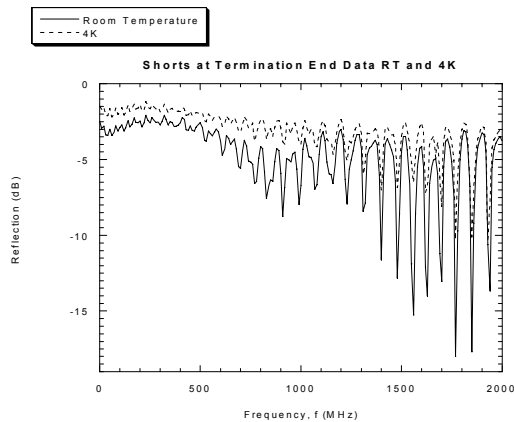

FIG 4: Picture of the semi rigid coax (large diameter) connected to the test transmission lines

The results obtained at room temperature (RT) and 4.2 K the entire line at shorted at point A are shown in figure 5.



(a)



(b)

FIG 5. Reflected signal amplitude relative to the incident amplitude versus frequency when line is shorted at point A of Fig. 4 for the CuNi coax cable (a) and NbTi coax cable (b)

Similar measurements were also made with the line shorted at point B of Fig. 4 to obtain the reflected power from the semirigid coax cable. The results of these measurements were subtracted from the results of the measurements taken with the short at the end of line at point A. In doing so, we subtract the losses due to the semi rigid coax and the final results give us a picture of the power losses due to the test lines themselves. The differences from the two short circuit tests when the test lines are lowered into liquid Helium are shown in figure 6.

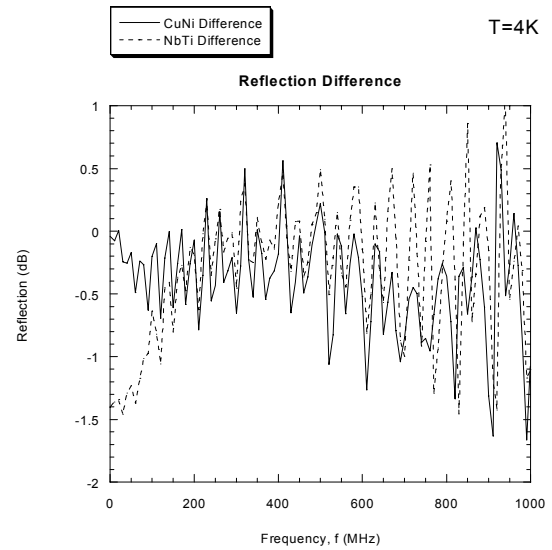

FIG 6. Difference in reflected signal amplitude between shorts at the end of the test transmission line (point A on Fig 4) and shorts at the end of the semi rigid coax (point B on Fig 4) when test lines are at $T=4K$.

The method of taking the difference in reflection is more valid at the lower frequencies. At higher frequencies, the reflection oscillations for the two different measurements differ more in their phase shifts. However, from the lower frequency measurements, it can be seen that the loss in power for both lines is small. Either line would transfer RF power efficiently.

The characteristic impedances of the combined superconducting and semirigid coaxial transmission lines at 4.2 K, obtained by terminating the combination at point A of Fig. 5, are shown in figure 7.

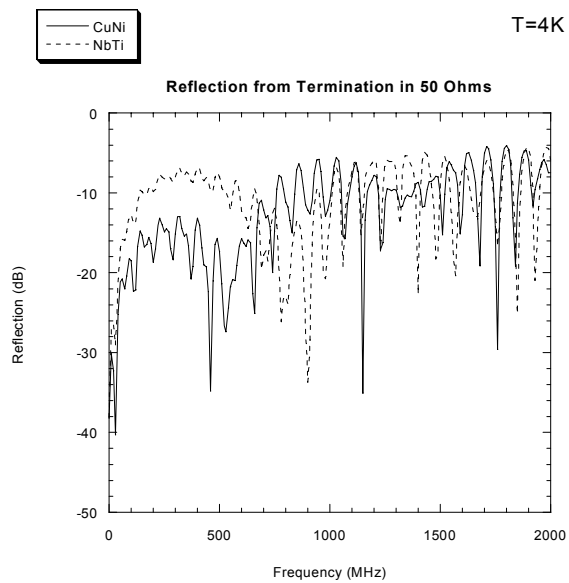

FIG 7. Reflected signal amplitude relative to the incident amplitude versus frequency when test lines are terminated a 50Ω chip resistor.

Both lines have little reflection at all frequencies, although in the lower frequency range, the CuNi line appears to have a significantly lower reflection coefficient than the NbTi line. This indicates that the CuNi line has an impedance closer to 50Ω than the NbTi line.

Conclusions

It was significantly easier to construct CuNi transmission line than the NbTi transmission line. The NbTi wire is easily inserted into the CuNi tubing, and the tubing is then easily soldered to another section of coax. The NbTi foil, on the other hand, is brittle, easily breaks and difficult to mold into a cylindrical shape. For construction purposes and mechanical stability, it is more practical to use the CuNi tubing than the NbTi foil for the outer conductor.

Both transmission lines show little power loss when short circuited. Either line would transfer RF power efficiently with little loss.

The CuNi transmission line appears to better match the 50Ω impedances of the network analyzer and the semi rigid coax. The NbTi transmission line also shows little reflection from 0-2 GHz, but the CuNi line shows even less reflection.

Because the CuNi line has low losses, is easier to build and has an impedance closer to 50Ω than the NbTi transmission line, we find that the CuNi

transmission line with NbTi inner conductor is the better line for use in the dilution refrigerator system.

Acknowledgements

We thank Francoise Queval and Walter Gekelman for organizing this program. We also thank Stuart Brown for his help and guidance. Support was provided by NSF Grants PHY-0243625 and DMR-0334869.

[1] D.S. Betts. *Refrigeration and Thermometry Below One Kelvin* (Sussex University Press, London, 1976), p. 24, 29, 30

[2] Charles Kittel. *Introduction to Solid State Physics* Vol. 6 (John Wiley & Sons Inc., New York, 1986), p. 150

[3] W.G. Clark, Notes on Transmission Lines (unpublished).